

KUBOTA TRACKED
DUMPERS

KC300H-5
KC300HR-5



Engine output (PS):

KC300H/HR-5 :
46.3 / 46.3

Machine weight (kg):

KC300H/HR-5 :
2.750 / 2.750

Payload (kg):

KC300H/HR-5 :
2.875 / 2.875

Compact performance and

Compact, powerful and versatile, the KC300-5 are designed for
The new KUBOTA KC300-5 can transport a large quantity of material in a short
time and trouble. With its fast traveling speed and loading capacity, it works in
various ground conditions.

Unloading operation

Unloading operation is fast and easy. The profile of the dump skip of every model has been designed to ensure a quick discharge of the material. With a dumping angle of 55° (H version) and 84° (HR version), all materials are discharged very easily. In addition, the rotary function (180°) for the HR version and the three ways dump for H version allows emptying sideways in all conditions when filling a trench for example.

Hydrostatic transmission (HST)

The KC300-5 crawler dumpers feature a variable-speed, 2-pumps and 2-motors and clutch less Hydrostatic Transmission. This allows it to perform counter-rotation maneuvers. The advanced transmission offers smooth control. The operator can select the most adapted speed for the job site, and can easily shift from High speed (up to 11 km/hr) for flat surfaces to Low speed (up to 6 km/hr) for rougher terrains. The HST system helps make working and travelling more efficient and productive, and it offers a smoother ride therefore reducing operator fatigue.

Undercarriage with triple flange and short pitch

The KC300-5 track mechanism features 12 triple-flange rollers. Eight of which are mounted on an oscillating support. This guarantees great stability on slopes and rough terrain. The short pitch track offers a smooth ride for optimal comfort at high speed.



Performance

With their fast travelling speed (11 km/h) and a loading capacity of 2875 kg, the KC300-5 can easily transport a large quantity of material in a short time. With their powerful tracked undercarriage, they can work in different ground conditions. The KC300-5 can easily overcome obstacles thanks to a rear attack angle of 26° and a ground clearance of 330 mm.

d remarkable design.

r optimum comfort.

aterials easily and quickly saving you

capacity of 2875 kg is the best to working in

KC300HR-5
(180° rotary dumping function)



Loading capacity

Thanks to the great versatility, with a maximum loading capacity of 2875 kg and a volume of ff the KC300-5 is a real multi-purpose dumper that will give you the opportunity to carry all type of materials.

KC300H-5 (3-way dump)



Multifunction joystick and LCD control panel with rear view camera

The LCD control panel is conveniently located to the right side of the operator. Whatever the driving direction, the operator always has excellent driveability of the dumper and good visibility of the dashboard indicators. The LCD monitor integrates a rear view camera. Therefore, the operator can concentrate on the job with less fatigue. A stop and start button on the console, allows to switch off the engine without turning the ignition key each time. Six standard LED headlights (four forward and two behind) guarantee perfect illumination. All these elements significantly increase safety on construction sites.



SERVICE / SAFETY

A fully opening bonnet and optimum arrangement of internal parts for quick and efficient service and a shorter downtime.

Tie down points, lifting points and towing hook

To make transportation easier and safe, four anchor points give the opportunity to secure during transportation from one point to the other. Easy access to tie down points guarantee best efficiency in order to avoid the operator injury. Once the skip is in the raised position, you can use the four lifting hooks to lift the machine. A towing hook is also available at the back of the chassis.



Front Bumpers

A front bumpers protect the machine and reduce potential damages. Two LED-working lights are protected and integrated behind this strong bumper.

Anti skid step

Getting on and off the machine very easily with the safe and conformable anti-skid step. This definitely minimise risk of accident of the operator.



KUBOTA ORIGINAL DI (STAGE-V) ENGINE WITHS CRS AND DPF MUFFLER

Kubota Original DI Engine equipped with CRS and DPF, Kubota's direct-injection engines are now fully Stage-V compliant. The new and improved DPF reduces maintenance by increasing the service intervals for both the regeneration filter and ash cleaner.



Safety, ROPS / FOPS canopy

For maximum safety of the operator, the KC300-5 feature a ROPS / FOPS canopy completely in shape and a seat belt for additional safety. Two ergonomic handles perfectly sized for the operator's hand facilitate access to the driving post and supporting the driver during travel.

Full reversible driving position

The Kubota KC300-5 crawler dumpers feature a deluxe reversible driving position, which allows the operator to turn through 180 degrees and face the opposite direction of travel. Since the multifunctional joystick are integrate in the right seat's console, operation is seamless, even in reverse. This helps create a safer and easy environmental for the driver.



Maintenance

The fully open engine hood allows good access for easy maintenance. Daily engine checks are concentrated in one place. The battery is located outside the engine compartment in order to keep it cool.



Dimensions

KC300HR-5

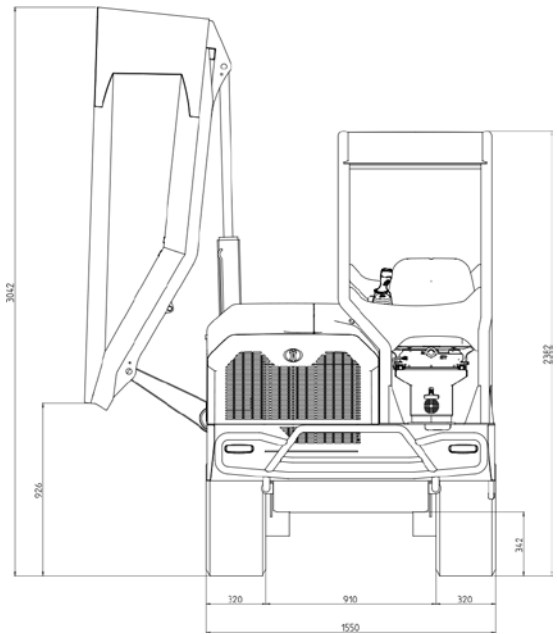
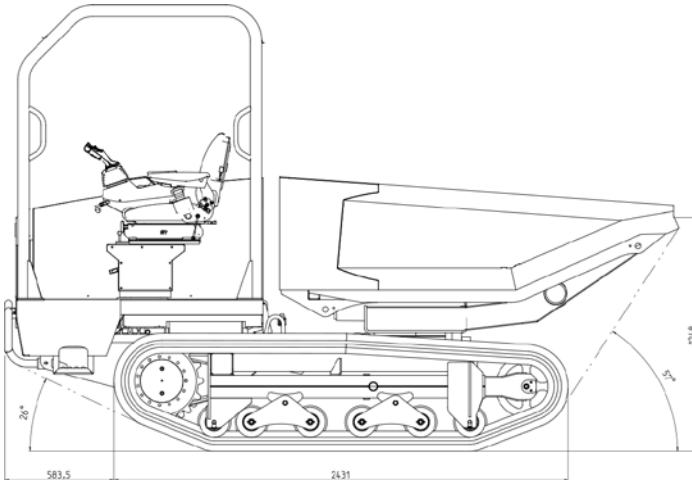

Unity: mm

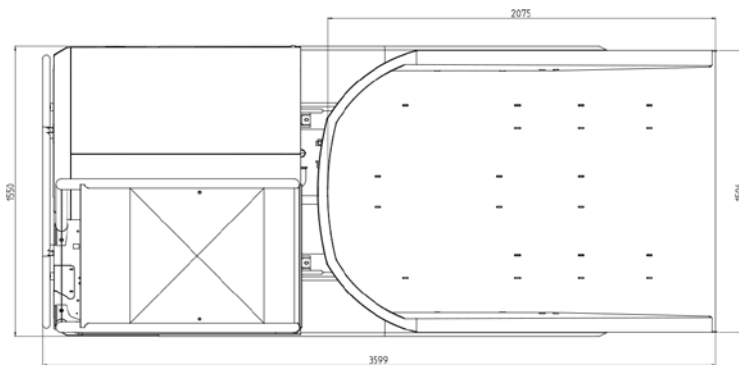

KC300H-5

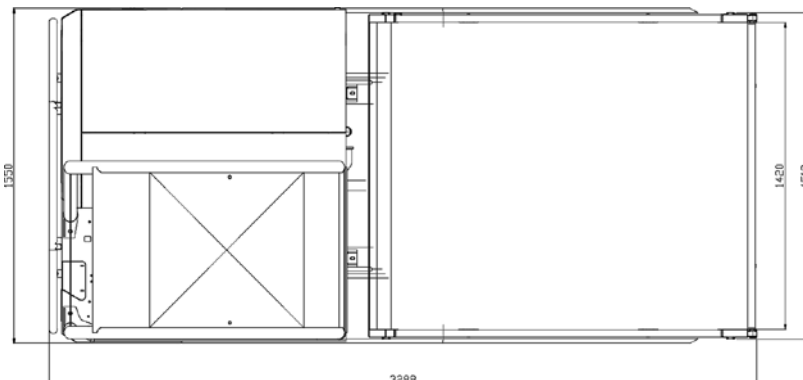
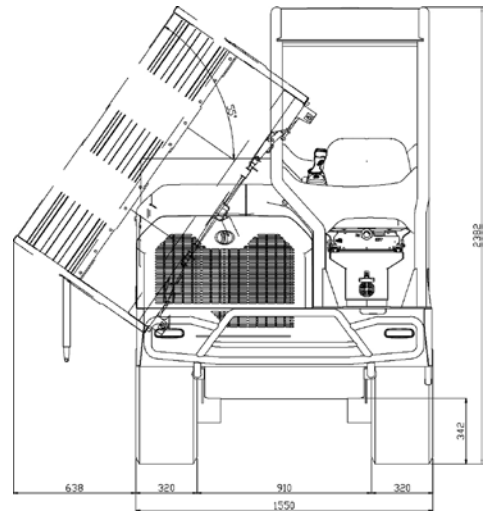
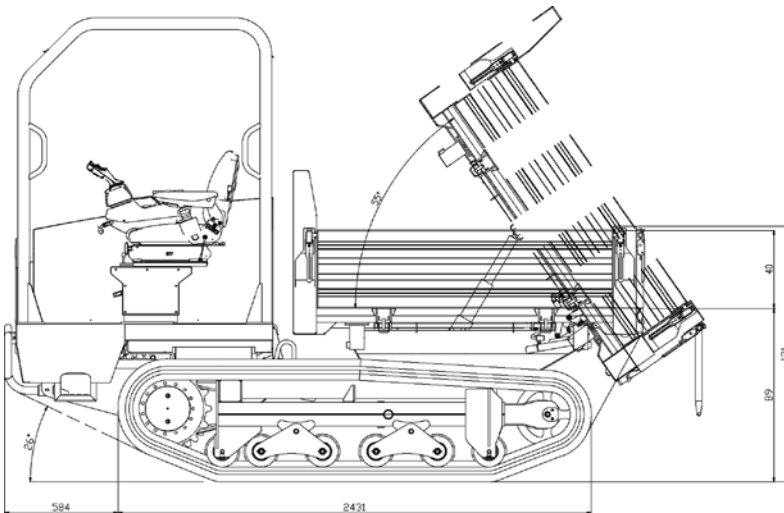

Specifications

Model name		KC300H-5	KC300HR-5	
Engine	Manufacturer	Kubota		
	Model	V2403 (Stage V)	V2403 (Stage V)	
	Output	kW (PS)	34,1 (46,3)	
		rpm	2400	
	Displacement	cc	2403	
Cooling system	Water cooled			
Operating Weight	kg	2750		
Max loading capacity	kg	2875		
Bucket tilting system	Hydraulic			
Dumping direction	3-way dump		180° rotary dumping	
Transmission	Typology	Hydrostatic transmission HST		
	Hydraulic pumps	2 variable pumps (Rexroth)		
	Hydraulic flow of pumps	l/min	2 x 54	
	Hydraulic motor	Radial piston engine		
	Max pressure	bar	350	
Machine dimensions	Length	mm	3288	3599
	Height	mm	2382	
	Width	mm	1550	
Internal skip dimensions	Length	mm	1637	2075
	Width	mm	1440	1506
	Height	mm	400	-
	Dumping angle	degrees	55°	84°
	Struck Volume (ISO6483)	m ³	1,35	1,49
	Rated Capacity (ISO6483)	m ³	0,89	1,09
Undercarriage	Ground clearance	mm	330	
	Approach angle	degrees	26° (front) / 57° (rear)	
	Pitch	mm	1950	
	Rubber shoe width	mm	320	
	Lower rollers	quantity	6	
Driving speed (forward/reverse)	1st speed	km/h	0 ~ 6	
	2nd speed	km/h	0 ~ 11	
Max gradeability	degrees	Front side 20° / Lateral side 25°		
Fuel tank capacity	liters	45		
Hydraulic tank capacity	liters	51		

Available models and versions

Type	Standard Model	Luxury Model (HI)
LCD color monitor and rear view camera	●	●
Joystick for tracks and skip controls	●	●
2 pedal accelerators		●
2 front LED lights	●	●
4 LED lights on the canopy		●
Engine start/stop button and accelerator lock (for fix rpm)	●	●



KUBOTA EUROPE S.A.S.

19, rue Jules Verceyusse
Zone Industrielle - CS50088
95101 Argenteuil Cedex France
Téléphone : (33) 01 34 26 34 34
Télécopieur : (33) 01 34 26 34 99

★ All images shown on this document are solely made for this brochure.
The method of use of the machine, the safety devices and protective clothing must comply with the legal safety regulations.